

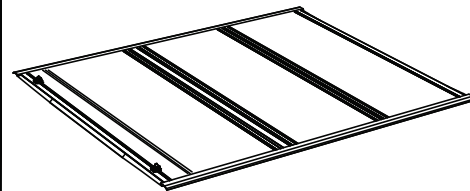

Premium Folding Cover



Fits: TFX2705- 2020 Jeep Gladiator JT 5 ft Bed



30-60 min



Cutting Required



Drilling Not Required



THE ARMIS TONNEAU COMES FULLY ASSEMBLED.



support@trailfx.com



REMOVE CONTENTS FROM BOX. VERIFY ALL PARTS ARE PRESENT.



1 866 638 4870



READ INSTRUCTIONS CAREFULLY BEFORE STARTING INSTALLATION.



LIMITED LIFETIME WARRANTY

KS-G4

PARTS LIST OF COMPONENTS

| PN | Part Description / Qty | PN | Part Description / Qty |
|----|--|----|-----------------------------|
| 1 | Hard Folding Cover (1) | 8 | Front Mounting Brackets (2) |
| 2 | Left Mounting Rail (1) | 9 | Rear Mounting Brackets (2) |
| 3 | Right Mounting Rail (1) | 10 | Female Buckle Kit (1) |
| 4 | Mounting Bolts- (10- M6 Flange Head Bolts) & Nuts (4-1/4-20) | | |
| 5 | Bulkhead Seal (1) | | |
| 6 | Pre-Staked Cover Retainer Assemblies (2) | | |
| 7 | Drain Tubes (2) | | |

Components

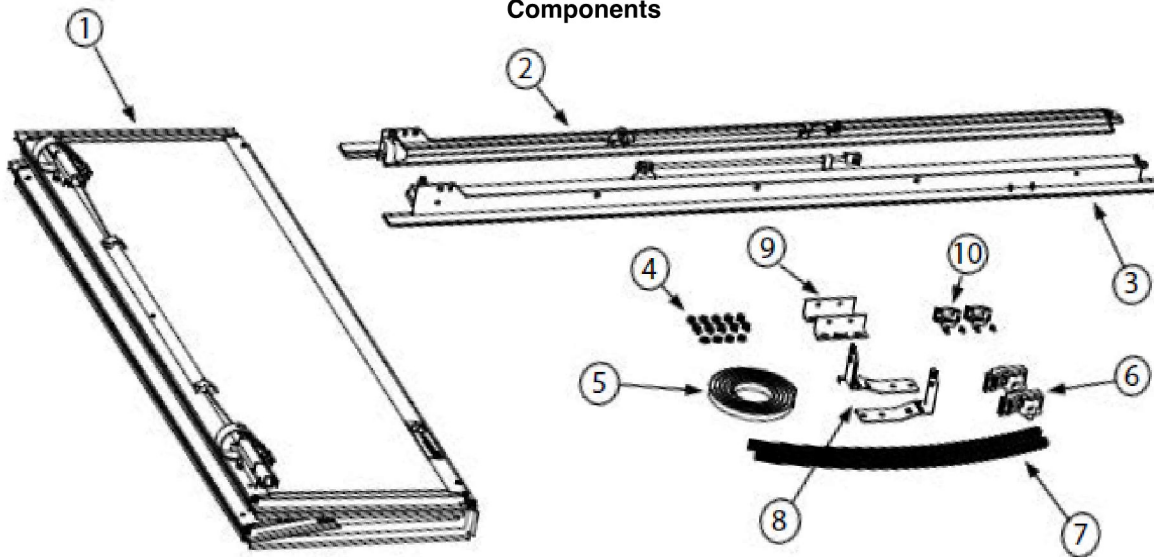

Tools Required

Ratchet & 7/16" Socket & 10MM Wrench/ Socket

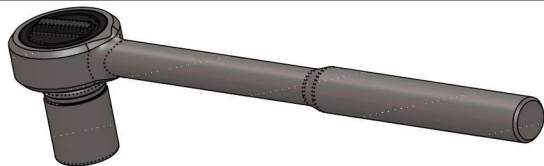

INSTALLATION PROCEDURE

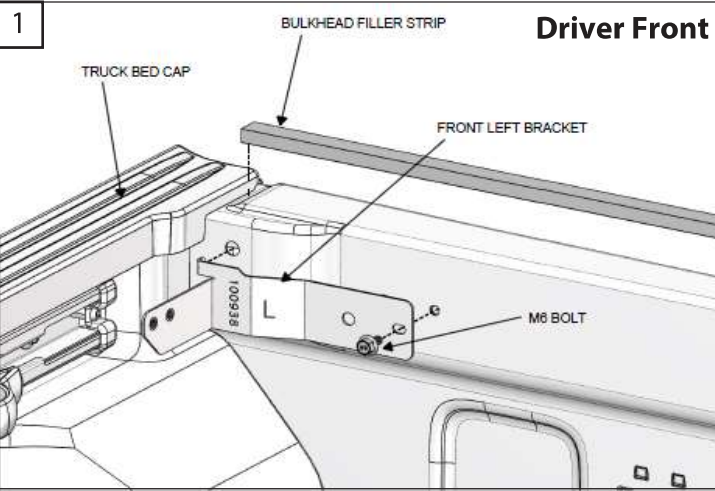

1. Install the bulkhead seal on top of the front bulkhead of the bed, centering the bulkhead seal front to back. Make sure to place the bulkhead seal, so that both ends set flush against the inside edge of the plastic bed rail caps, (driver to passenger side). Trim to fit.

Note: If your Jeep is equipped with the track system, the front track must be removed at this time to allow for the installation of the front brackets.

Next locate the driver's side front left bracket (labeled with an L as shown in Drawing 1)(Passenger side labeled R). Locate the pre-bent tab on the front bracket and place in the upward most hole located towards the front corner of the bulkhead on both sides. Repeat on passenger side.

Note: If you previously removed your front track, place the front track over the face of the 2 front brackets and reinstall front track.

Place an M-6 flange head mounting bolt through the slotted hole in the mounting bracket (same hole used for the front track). The M-6 bolts for the front brackets (and front track) can now be tightened at this time.

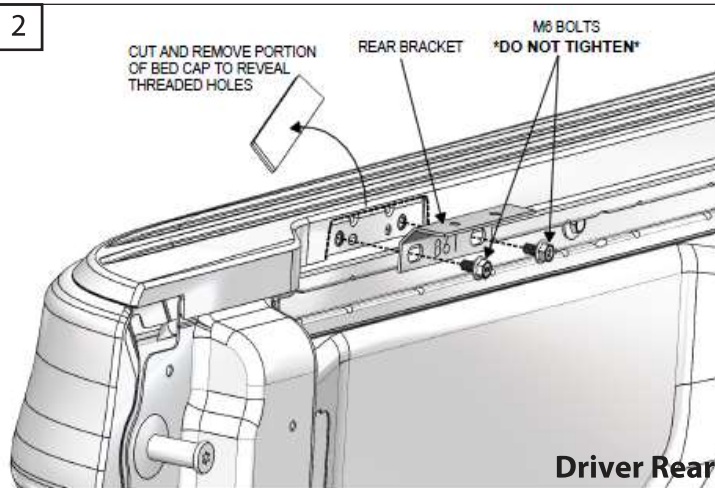

2. Locate the outlined section on the inside of the bed cap towards the tail light well at the rear of the bed. Cut and remove the outlined section of bed cap to reveal threaded holes. Repeat process for both Driver and Passenger side. Locate the 2 rear brackets and install (as shown in Drawing 2), using 2 M-6 flange head mounting bolts per side. Do not tighten, leave slightly loose at this time.

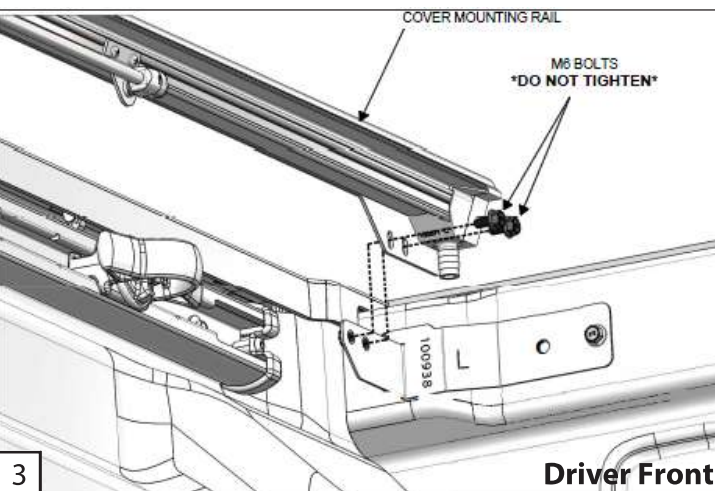

3. Locate the Driver side mounting rail. Using 2 M-6 flange head mounting bolts, install the driver side mounting rail to the driver side front bracket (as shown in Drawing 3). Do not tighten, leave slightly loose until rear mounting bolts are installed. Repeat process for passenger side.

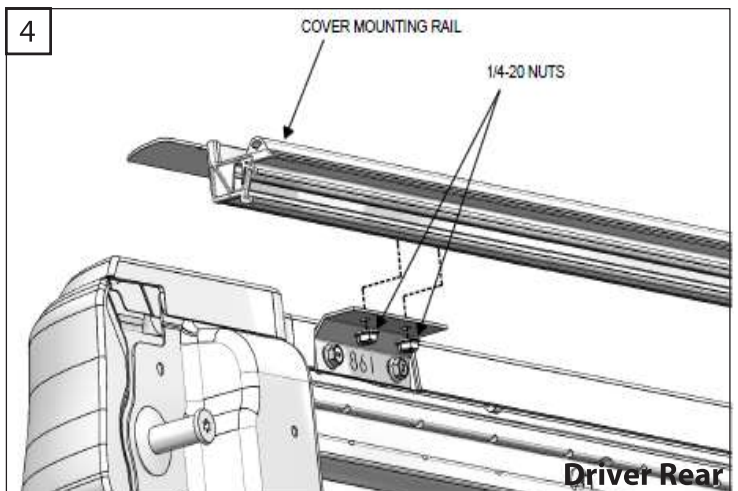

4. Install the rear portion of each mounting rail, (as shown in Drawing 4) Locate the 2 studs on the bottom side of the mounting rail and place the studs through the 2 holes in the rear bracket. Use 2 (1/4-20) nuts, thread on to the studs and tighten, using a 7/16" socket. Repeat process for opposite side.

5

APPLY PRESSURE WHILE TIGHTENING BOLTS TO ASSURE RAIL IS SEALED AGAINST BED CAP

5. Once the mounting rails are in place, apply pressure while tightening the bolts to assure rails are sealed against the bed cap. (The use of a ratchet, 10MM socket or wrench for the M-6 bolts is recommended). The assistance of another person may be needed for this step to get the proper seal.

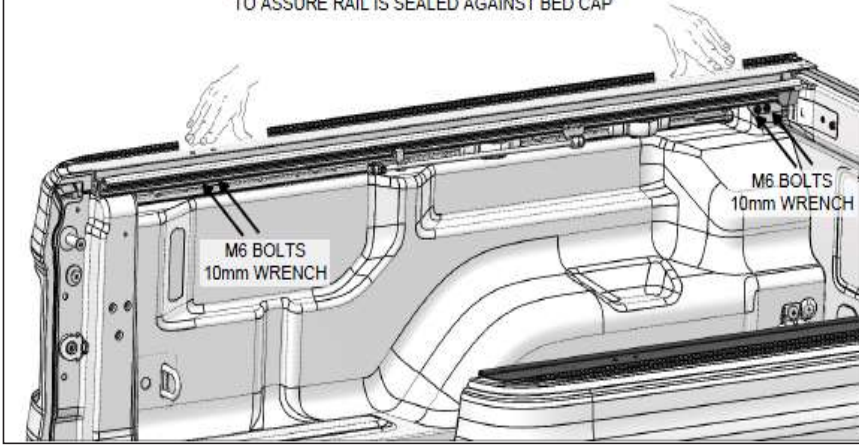

6 & 7

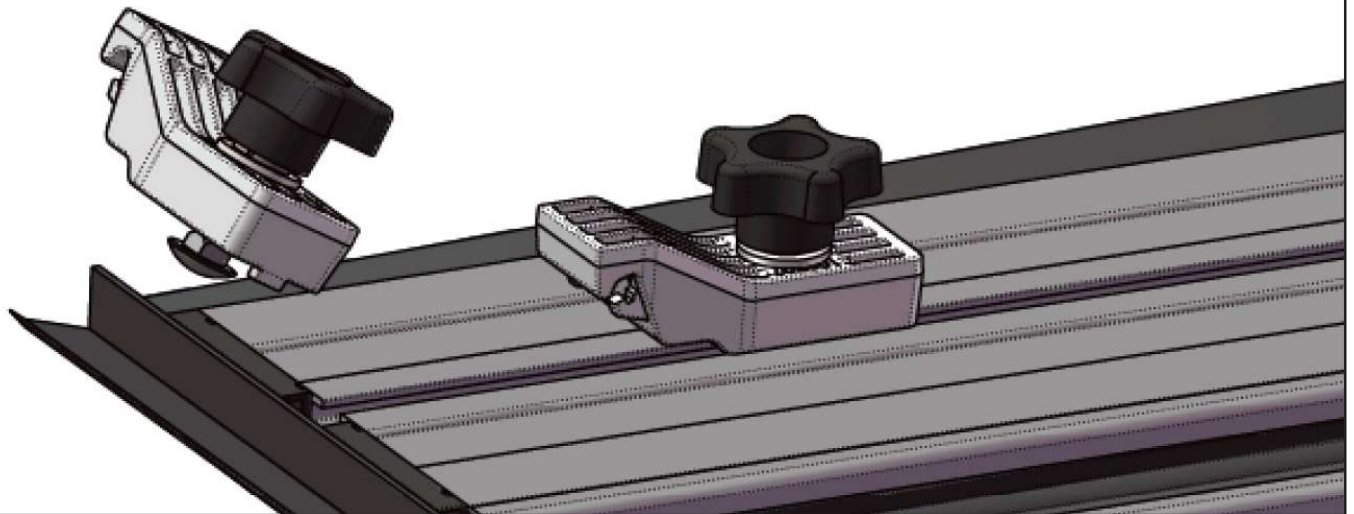

6 & 7. Slide the two front pre-staked cover retainer assemblies into the track on the underside of the tonneau cover, do not remove bolt from assembly.

8

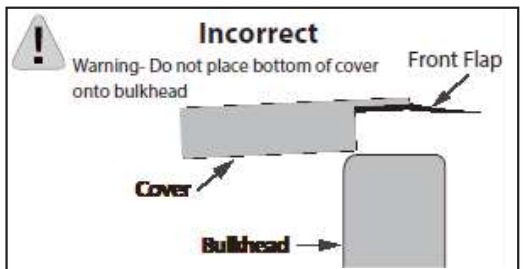
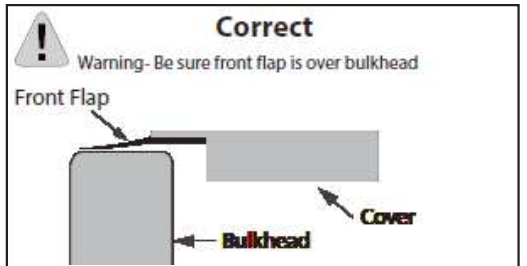

8. Place the tonneau onto the mounting rails with the smallest panel towards the cab of the truck and with the front flap covering the bulkhead.



9. Carefully unfold the cover. Position the cover so it is centered side to side and front to back on the truck bed.



10. Test the rear latching assembly for smooth operation as this is the best indicator of the cover being positioned correctly. Be sure the latches on both sides are engaging with the cover mounting rail.



11 & 12. Once the cover is located correctly, fold the cover to the open position. Pull the release cables on the rear panel to release it from the side rail. Take care to fold it gently so the position of the cover is not disturbed.

WARNING: DO NOT TRY TO SECURE THE COVER WITH THE RETAINER CLAMPS ONTO THE FRONT CARGO RAIL. (IMAGE A)



INCORRECT

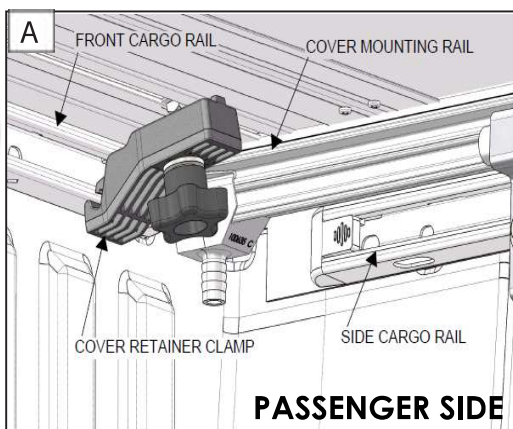

CORRECT

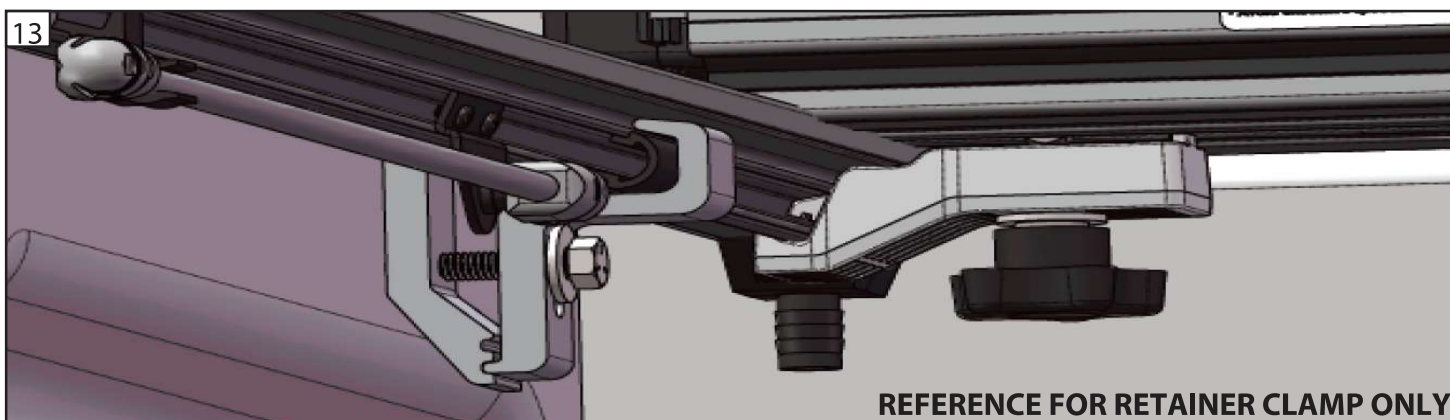
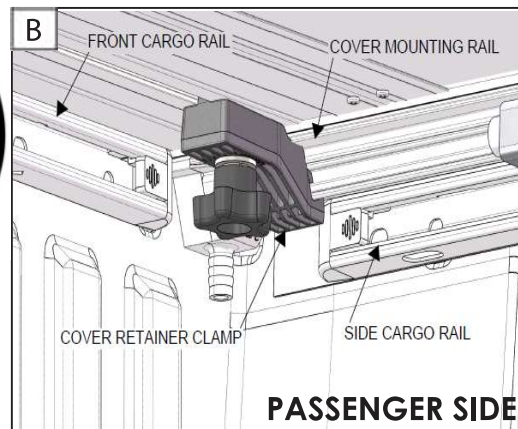

13. Once in the open position place the front pre-staked cover retainer assemblies, (retainer clamp, flat washer, lock washer, star knob and mounting bolt), underneath the cover in the slotted groove so that the retainer clamp engages into the mounting rail and hand tighten. **Note: Engage the retainer clamps onto the cover mounting rail as shown (IMAGE B & 13).** Be sure the front retainer clamp is clamping to the side rail correctly. Test the cover again for proper operation, adjust as needed, then tighten the star knobs.



14. Attach the prop rod to the side rail.



15. Attach the drain tubes to the fittings at the front of the bed rail and position the tubes to divert water out of the truck bed. This can be done by placing the tube behind a bed liner, through an existing hole in the bed, or by drilling a 5/8" hole in the bulkhead or bed floor.

Note: If you choose to place the tube behind your bed liner, be sure your drain holes in the bed are not clogged.

Note: If you choose to drill holes, check to make sure the area is free and clear of any obstructions behind the bed. Be sure to clean up any shavings.

OPERATION INSTRUCTIONS



1 & 2. To open the cover: Lower the tailgate and pull the cable. While pulling on the cable lift the panel up and towards the cab, repeat for the next panel.

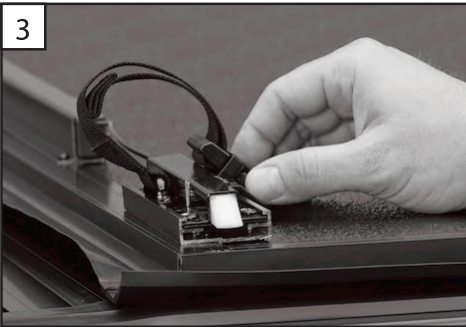

3, 4 & 5. If this is as far as you would like to open the cover, you can secure it in this position. Release the strap from the stowed position by squeezing the tabs. Attach the buckle at the bulkhead, pull the strap to take up the slack and secure the cover. Repeat this for the opposite side.



Warning! Do not lean the cover against cab or damage to the truck and/or cover can occur.

6 & 7. Pull the cable on the third panel and fold the cover up towards the cab.

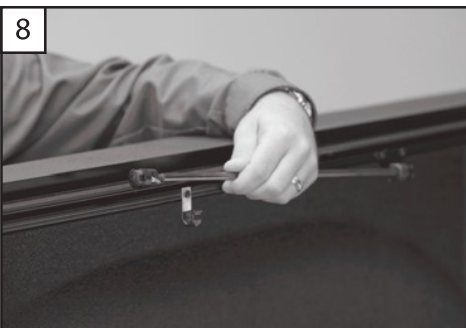

8 & 9. Snap the prop to the mount on the cover, repeat for the other side. To close simply reverse this process.

PRODUCT CARE

- Clean with soap and water only.
- Cover must be secured when vehicle is in motion. See instructions for recommended driving positions. An unsecured cover can result in damage not covered by this warranty.

WARRANTY COVERAGE

Keystone Automotive Operations Inc. (KAO) warrants this product to be free of defects in material and workmanship at the time of purchase by the original retail consumer. KAO disclaims any other warranties, express or implied, including the warranty of fitness for a particular purpose or an intended use. If the product is found to be defective, KAO may replace or repair the product at our option, when the product is returned prepaid, with proof of purchase. Alteration to, improper installation, or misuse of this product voids the warranty. KAO's liability is limited to repair or replacement of products found to be defective, and specifically excludes liability for any incidental or consequential loss or damage. The repaired or replaced tonneau will be in warranty for the remainder of the original warranty period.

FAQ:

1. How difficult is it to install the tonneau cover?

Installing of tonneau cover is easy, please follow the steps in installation manual carefully.

2. How do I clean my tonneau cover?

Wash the tonneau same as your truck. We recommend using soap and water.

3. Will the tonneau cover scratch my paint?

No. Please follow the installation instruction manual carefully to avoid scratching paint.

4. Missing or Excess Hardware?

Re-check hardware count as per the part list.

5. Why is my tonneau cover not installing properly?

Ensure year, make, model, cab length and bed size of your vehicle is listed in the application and installation steps are followed correctly.

CHECK OUT THESE OTHER TRAIL FX PRODUCTS!



SIDE BARS



ROCKER GUARD



BED RAILS



RUNNING BOARDS